

Administrative Use Only

Date Submitted \_\_\_\_\_  
Filing Fee - \$100.00 Date Paid - \_\_\_\_\_  
Date Advertised \_\_\_\_\_

Case Number \_\_\_\_\_  
Accepted By \_\_\_\_\_  
Date Property Posted \_\_\_\_\_

**SPECIAL USE PERMIT APPLICATION**

**CITY OF LEXINGTON**

1. Applicant's Name USA Communications
2. Applicant's Address 2123 Central Ave STE 200, Kearney, NE 68847
3. Applicant's Telephone Number 308-698-1410
4. Owner's Name Ron Huss
5. Owner's Address 300 Plum Creek Pkwy, Lexington, NE
6. Owner's Telephone Number 308-627-7285
7. Purpose of Special Use Permit Erect a broadband comm. tower, 150ft free-standing
8. Present Zoning M-2, Heavy Industrial
9. Within City Limits Yes Within Zoning Jurisdiction Yes
10. Legal Description LOT 1 Tract G, Lexington NE (East End)
11. Street Address of Property or Approximate Location East end of 300 Plum Creek Pkwy lots,  
approximately 300ft away from current cellular communications tower previously approved by the city  
in the same relative location.
12. Site Plan (if applicable) See Attached for approximate site building location

I/We the undersigned do hereby acknowledge that I/We do fully understand and agree to comply with the provisions and requirements for an application for a special use permit as described above. I/We the undersigned do hereby agree to allow City of Lexington employees or agents working for the City of Lexington, to enter the above referenced property as it pertains to this application.

  
Signature of Owner

  
Signature of Applicant

# USA Communications Proposed Tower Site Location

150ft AGL Self-Supporting Structure (No guy wires)

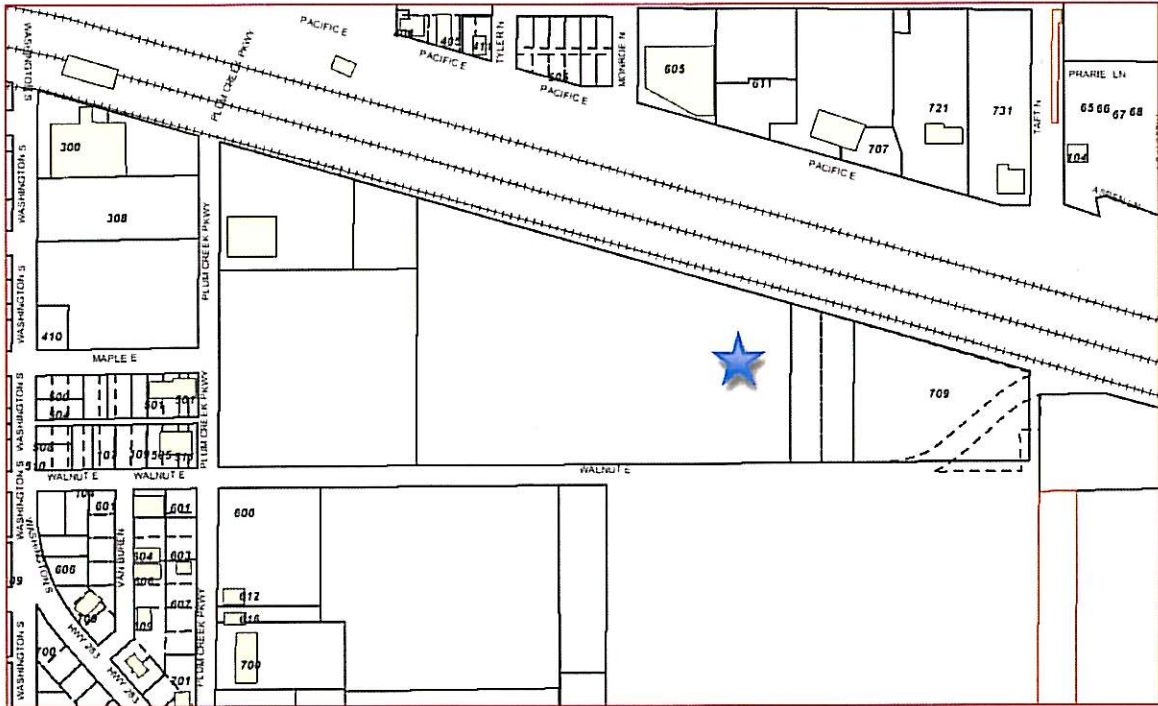

\*Maps shown are not identical scale.



\* Structure Type Model

ELEVATION

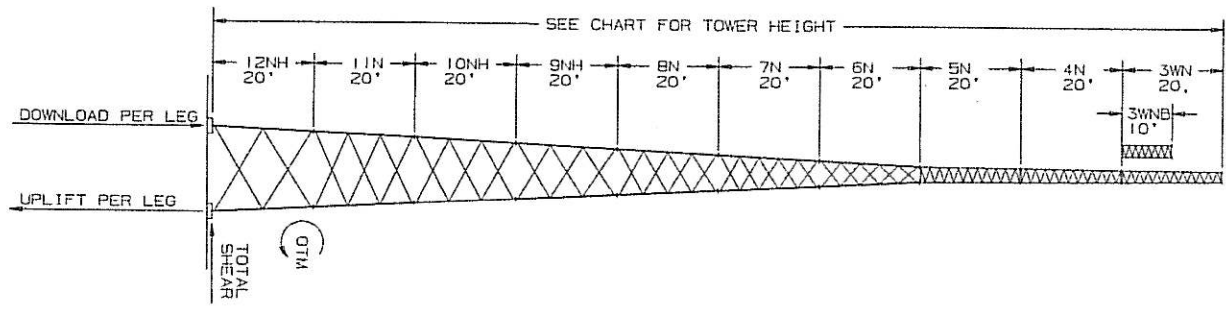

TOWER ASSEMBLY NUMBER	TOWER HEIGHT (FEET)	TOP SECTION	BASE SECTION			ALLOWABLE PROJECTED AREA (SQ. FT.)				BASE REACTIONS			
			PART NO.	# A-BOLTS 1/2 REQ'D	FACE SPREAD	TOWER TOP		30 FEET BELOW TOP		DOWNLOAD (POUNDS)	UPLIFT (POUNDS)	TOTAL SHEAR (POUNDS)	OTM FOOT (POUNDS)
						ROUNDS OR FLATS	ROUNDS OR FLATS	ROUNDS OR FLATS	ROUNDS OR FLATS				
SS040D90	40	3WN	4N	SB4	2' 2	16.7	10.0	20.0	12.0	20,800	19,800	1,700	38,100
SS050D90	50	3WNB	5N	SB5	2' 6	16.7	10.0	20.0	12.0	27,900	26,600	1,950	58,900
SS060D90	60	3WN	5N	SB5	2' 6	14.2	8.5	17.5	10.5	33,700	32,400	1,930	71,400
SS070D90	70	3WNB	6N	5/8X42AB	4' 6 1/4	14.2	8.5	17.5	10.5	27,100	25,500	2,760	103,100
SS080D90	80	3WN	6N	5/8X42AB	4' 6 1/4	12.5	7.5	15.8	9.5	31,300	29,600	2,820	119,300
SS090D90	90	3WNB	7N	5/8X42AB	6' 6 3/4	12.5	7.5	15.8	9.5	31,100	29,100	3,850	169,900
SS100D90	100	3WN	7N	5/8X42AB	6' 6 3/4	10.0	6.0	13.3	8.0	33,100	30,900	3,830	180,600
SS110D90	110	3WNB	8N	5/8X42AB	8' 6 3/4	10.0	6.0	13.3	8.0	36,000	33,400	5,070	255,500
SS120D90	120	3WN	8N	5/8X42AB	8' 6 3/4	8.3	5.0	11.7	7.0	38,100	35,400	5,100	270,300
SS130D90	130	3WNB	9NH	5/8X42AB	10' 6 3/4	8.3	5.0	11.7	7.0	42,900	39,700	6,520	375,800
SS140D90	140	3WN	9NH	5/8X42AB	10' 6 3/4	6.7	4.0	10.0	6.0	44,500	41,200	6,540	389,800
SS150D90	150	3WNB	10NH	3/4X48AB	12' 7 1/4	6.7	4.0	10.0	6.0	50,900	47,000	8,280	532,100
SS160D90	160	3WN	10NH	3/4X48AB	12' 7 1/4	5.8	3.5	8.3	5.0	52,700	48,700	8,330	550,900
SS170D90	170	3WNB	11N	7/8X60AB	14' 7 7/8	5.8	3.5	8.3	5.0	60,900	56,000	10,570	739,500
SS180D90	180	3WN	11N	7/8X60AB	14' 7 7/8	5.0	3.0	7.5	4.5	62,900	57,900	10,650	763,700
SS190D90	190	3WNB	12NH	7/8X60AB	16' 8 3/8	5.0	3.0	7.5	4.5	73,000	66,900	13,060	1,007,000

\* ANCHOR BOLTS OR BASE PART NO.

**GENERAL NOTES**

- TOWER DESIGNS ARE IN ACCORDANCE WITH APPROVED NATIONAL STANDARD ANSI/EIA-222-E-1991 (NO ICE).
- EQUIVALENT FLAT-PLATE ANTENNA AREAS, BASED ON EIA RS-222-C, MUST NOT EXCEED THE AREAS SHOWN FOR FLAT MEMBER ANTENNAS.
- TOWER DESIGNS ASSUME ALLOWABLE PROJECTED AREAS ARE SYMMETRICALLY PLACED ON THE TOWER.
- DESIGNS ASSUME ONE 7/8 LINE TO TOP AND TWO 7/8 LINES TO 30 FEET BELOW TOP, ONE PER FACE.
- DO NOT INSTALL OR DISMANTLE TOWERS WITHIN FALLING DISTANCE OF ELECTRICAL AND/OR TELEPHONE LINES.
- TOWER ERECTION AND DISMANTLING MUST BE BY QUALIFIED AND EXPERIENCED PERSONNEL.
- INSTALL WARNING PLATE (P/N ACWS) IN A HIGHLY VISIBLE LOCATION.
- ALL ANTENNA INSTALLATIONS MUST BE GROUNDED IN ACCORDANCE WITH LOCAL AND NATIONAL CODES.
- FOR SECTION ASSEMBLY DETAILS AND PART NUMBERS SEE DRAWING E680101.
- FOR ADDITIONAL BRACING, GROUTING AND DRAINAGE DETAILS SEE DRAWING SK720305.
- FOR TAPERED TOP DETAILS SEE DRAWING SK670407.
- ALL TOWERS WITH 3WN TOP SECTION PROVIDED WITH (P/N 3TT) TAPERED TOP.
- ALL TOWERS WITH 3WNB TOP SECTION PROVIDED WITH (P/N 4TN) TAPERED TOP.
- FOR STEP BOLT DETAILS SEE DRAWING B651264.
- FOR FOUNDATION DETAILS SEE DRAWING D870483.

RI	REV. NOTE 1 WAS EIA-222-D	11-11-81	RNB	OTZ	...
No. Δ Revision Description					
THIS DRAWING IS THE PROPERTY OF R O H N. IT IS NOT TO BE REPRODUCED, COPIED OR TRACED IN WHOLE OR IN PART WITHOUT OUR WRITTEN CONSENT.					
<b>R O H N</b>					
Scale:	AS SH	By:	WCU	Date:	9/2/87
Drawn:	WCU	Date:	9/2/87	Title:	
Checked:	GPW	Date:	9/30/87	40' TO 190' MODEL SSV TOWERS	
App. Eng.:	RAM	Date:	9/30/87	90 MPH WIND SPEED ANSI/EIA-222-E	
App. Spec.:	AE	Date:	2-12-88	( NO ICE )	
DRAWING NO.: CB70699 RI					

SSV-9

FAA Form 7601 Approval for Study  
 Working with Lexington Airport Authority  
 for final approval. Will comply before  
 construction begins.



Federal Aviation  
 Administration

Notice of Proposed Construction or Alteration - Off Airport

Project Name: USA C-000157853-10 Sponsor: USA Communications

Details for Case : USA Communications Lexington Tower

Show Project Summary

<b>Case Status</b>		<b>Date Accepted:</b> 10/18/2010	
ASN:	2010-ACE-2686-OE	<b>Date Determined:</b>	
Status:	Accepted	<b>Letters:</b>	None
		<b>Documents:</b>	None
<b>Construction / Alteration Information</b>		<b>Structure Summary</b>	
Notice Of:	Construction	Structure Type:	Antenna Tower
Duration:	Permanent	Structure Name:	USA Communications Lexington Tower
<i>if Temporary :</i>	Months: Days:	NOTAM Number:	
Work Schedule - Start:	12/01/2010	FCC Number:	
Work Schedule - End:	12/15/2010	Prior ASN:	
State Filing:	Not filed with State		
<b>Structure Details</b>		<b>Common Frequency Bands</b>	
Latitude:	40° 46' 22.80" N	Low Freq	High Freq Freq Unit ERP ERP Unit
Longitude:	99° 44' 1.30" W		
Horizontal Datum:	NAD83	<b>Specific Frequencies</b>	
Site Elevation (SE):	2385 (nearest foot)	Low Freq	High Freq Freq Unit ERP ERP Unit
Structure Height (AGL):	150 (nearest foot)	3650	3675 MHz 25 dBm
<i>* If the entered AGL is a proposed change to an existing structure's height include the current AGL in the Description of Proposal.</i>			
Requested Marking/Lighting:	None	<b>Other :</b>	
Recommended Marking/Lighting:			
Current Marking/Lighting:	N/A New Structure	<b>Other :</b> <input type="text"/>	
Nearest City:	Lexington		
Nearest State:	Nebraska		
Description of Location:	East end of sale barn lot in town, Lexington, NE.		
Description of Proposal:	Proposal to build a 150ft free-standing communications tower for wireless broadband point-to-multipoint connectivity.		



# UBIQUITI NETWORKS

TECHNICAL SPECIFICATIONS / DATA SHEET



## ROCKET M365: 3.65GHz HI Power 2x2 MIMO AirMax TDMA BaseStation

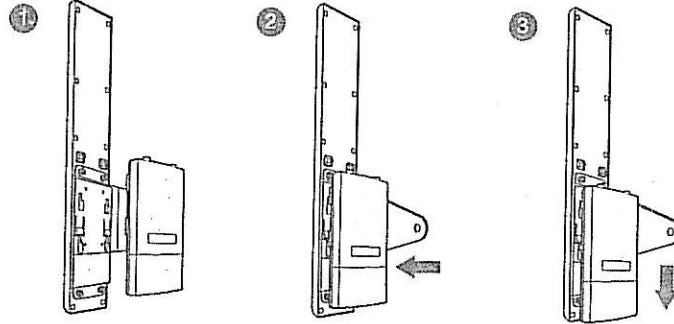

**airMAX**  
MIMO TDMA Protocol

**COMPATIBLE ANTENNAS**

AirMax Sector 3G-18-120  
Rocket Dish 3G-26

**SYSTEM INFORMATION**

Processor Specs	Atheros MIPS 24KC, 400MHz
Memory Information	64MB SDRAM, 8MB Flash
Networking Interface	1 X 10/100 BASE-TX (Cat. 5, RJ-45) Ethernet Interface

**REGULATORY / COMPLIANCE INFORMATION**

Wireless Approvals	FCC Part 90Y
RoHS Compliance	YES

**OPERATING FREQUENCY 3650MHz-3675MHz**

**TX POWER SPECIFICATIONS**

	DataRate	Avg. TX	Tolerance
AirMax	MCS0	25 dBm	+/-2dB
	MCS1	25 dBm	+/-2dB
	MCS2	25 dBm	+/-2dB
	MCS3	25 dBm	+/-2dB
	MCS4	24 dBm	+/-2dB
	MCS5	23 dBm	+/-2dB
	MCS6	22 dBm	+/-2dB
	MCS7	20 dBm	+/-2dB
	MCS8	25 dBm	+/-2dB
	MCS9	25 dBm	+/-2dB
	MCS10	25 dBm	+/-2dB
	MCS11	25 dBm	+/-2dB
	MCS12	24 dBm	+/-2dB
	MCS13	23 dBm	+/-2dB
	MCS14	22 dBm	+/-2dB
MCS15	20 dBm	+/-2dB	

**RX SPECIFICATIONS**

	DataRate	Sensitivity	Tolerance
Airmax	MCS0	-94 dBm	+/-2dB
	MCS1	-93 dBm	+/-2dB
	MCS2	-90 dBm	+/-2dB
	MCS3	-89 dBm	+/-2dB
	MCS4	-86 dBm	+/-2dB
	MCS5	-83 dBm	+/-2dB
	MCS6	-77 dBm	+/-2dB
	MCS7	-74 dBm	+/-2dB
	MCS8	-93 dBm	+/-2dB
	MCS9	-91 dBm	+/-2dB
	MCS10	-89 dBm	+/-2dB
	MCS11	-87 dBm	+/-2dB
	MCS12	-84 dBm	+/-2dB
	MCS13	-79 dBm	+/-2dB
	MCS14	-78 dBm	+/-2dB
MCS15	-75 dBm	+/-2dB	

**PHYSICAL / ELECTRICAL / ENVIRONMENTAL**

Enclosure Size	16cm length x 8cm width x 3cm height
Weight	0.5 kg
RF Connector	2x RPSMA (Waterproof)
Enclosure Characteristics	Outdoor UV Stabilized Plastic
Mounting Kit	Pole Mounting Kit included
Max Power Consumption	6.5 Watts
Power Supply	24V, 1A POE Supply Included
Power Method	Passive Power over Ethernet (pairs 4,5+; 7,8 return)
Operating Temperature	-30C to 75C
Operating Humidity	5 to 95% Condensing
Shock and Vibration	ETSI300-019-1.4

Ubiquiti Networks Inc., 91 E. Tasman Dr., San Jose, CA 95134 www.ubnt.com

\* Equipment to be installed on tower, 4 sectors (N,S,W,E)

# PLANNING COMMISSION CITY OF LEXINGTON

## DETERMINATION FORM

On **November 3, 2010**, the Lexington, Nebraska Planning Commission ,at its regular meeting, recommended **Approval** (Approval/Disapproval) of a **Special Use Permit Application** (Rezoning, Special Use, Subdivision, Variance, Zoning, Zone Appeal, Etc.) Request located at **Lot 1, Tract G** (Location) for **USA Communications**. (Name).

The Lexington Planning Commission made the following motion:

Motion by: Seth McFarland

Seconded by: Steve Smith

Motion: \_\_\_\_ Recommend approval of the Special Use Permit Application of with conditions that would ensure that removal of the tower would be completed should the use terminate.

---

---

---

---

---

---

---

---

Roll Call. Voting "aye" were Bennett, Heineman, Vazquez, Vivas, Evans, Smith, McFarland, Fagot. Motion carried.

Pamela Berke  
Planning Secretary