

# RESOLUTION

RESOLUTION # 2016-09

WHEREAS, there are federal funds available under Section 5311 of the Federal Transit Act and for the Nebraska Public Transportation Assistance Program, and

WHEREAS, the Community Action Partnership of Mid Nebraska – RYDE Transit desires to apply for said funds to provide public transportation in Dawson County.

NOW THEREFORE, BE IT RESOLVED the City Council of Lexington, NE, hereby instructs the Community Action Partnership of Mid Nebraska – RYDE Transit to apply for said funds.

Said funds are to be used for the Community Action Partnership of Mid Nebraska – RYDE Transit transportation operations in the FY 2016-2017 Application for Public Transportation Assistance.

Moved by \_\_\_\_\_

Seconded by \_\_\_\_\_

AFFIRMATIVE VOTE: \_\_\_\_\_

\_\_\_\_\_  
\_\_\_\_\_

Approved this 12<sup>th</sup> day of April, 2016.

\_\_\_\_\_  
MAYOR

Attested by: \_\_\_\_\_  
City Clerk

Local Funding Amount Match for 2016-2017: \$ \$21,000.00

## RYDE Transit - Dawson County 2016-2017

### Expenses

Personnel	\$ 240,274.00
Office Space	\$ 12,000.00
Postage	\$ 721.00
Communications	\$ 2,359.00
Travel	\$ 500.00
Memberships	\$ 200.00
Medical	\$ 375.00
Supplies	\$ 2,045.00
Advertising	\$ 1,023.00
Contract Services	\$ -
Printing/Office Supplies	\$ 1,079.00
Insurance	\$ 7,000.00
Maintenance/Repairs	\$ 21,563.00
Gas	\$ 22,875.00
Program Supplies	\$ 1,000.00

**Total Expenses**                    **\$ 313,014.00**

### Revenue

Donations	\$ 10,000.00
-----------	--------------

**Total Revenue**                    **\$ 10,000.00**

### Federal Funds

**\$ 181,551.00**

### State Funds

**\$ 60,731.00**

### Local Match

Dawson County	\$ 33,232.00
City of Lexington	\$ 21,000.00
Title XX/AMR	\$ 6,500.00

**Total Local Match**                    **\$ 60,732.00**

**Total Revenues**                    **\$ 313,014.00**

**\$ -**

2013-2014		Lexington		Cozad	Gothenburg & Farnam	Sumner, Eddyville, Overton	Total Out of Town	Total Boardings
July		489		24	42	82	148	637
August		468		52	29	70	151	619
September		443		48	27	46	121	564
October		478		49	28	108	185	663
November		441		27	30	73	130	571
December		556		29	29	58	116	672
January		615		50	27	89	166	781
February		603		31	23	63	117	720
March		683		20	22	90	132	815
April		670		29	32	101	162	832
May		743		33	38	79	150	893
June		668		35	23	79	137	805
	Total	6857		427	350	938	1715	8572

2014-2015		Lexington		Cozad	Gothenburg & Farnam	Sumner, Eddyville, Overton	Total Out of Town	Total Boardings
July		760		10	19	120	149	909
August		749		29	21	54	104	853
September		844		22	12	22	56	900
October		907		36	21	53	110	1017
November		731		27	30	73	130	861
December		728		22	26	40	88	816
January		807		23	23	42	88	895
February		790		25	15	33	73	863
March		847		15	21	54	90	937
April		952		24	17	80	121	1073
May		813		33	20	54	107	920
June		918		44	23	62	131	1047
	Total	9846		310	248	687	1247	11091

2015-2016		Lexington		Cozad	Gothenburg & Farnam	Sumner, Eddyville, Overton	Total Out of Town	Total Boardings
July		1050		67	17	56	140	1190
August		929		76	23	47	146	1075
September		1047		71	31	49	151	1198
October		1064		78	27	43	148	1212
November		866		92	22	38	152	1018
December		998		108	32	68	208	1206
January		914		128	35	52	215	1129
February		860		115	66	35	216	1076
March							0	0
April							0	0
May							0	0
June							0	0
	Total	7728		735	253	388	1376	9104



## **RYDE Transit Vehicle Purchase Procedure**

- 1. Announcement of Vehicles available on State of NE Contract Pricing which have met FTA Buy America Requirements**
- 2. Choose Vehicle Replacement or Additional Vehicle type for location**
- 3. Secure Federal Funding (80%)**
- 4. Secure Local Funding (20%)**
- 5. Publish Public Hearing Notice**
- 6. Public Hearing on Vehicle Purchase**
- 7. Review Public Hearing Comments**
- 8. Send vehicle order to NDOR**

**(Vehicle order package: Signed Application, Local Meeting Minutes (Resolution), Public Hearing Notice, Publication Proof, Attendance Sheet, Comments)**

## RYDE Transit Vehicle Request DCL

	Vehicle Cost	Local Share*	Dawson County	City of Lexington
Small Bus	\$55,000.00	\$12,100.00	\$6,050.00	\$6,050.00
10 Passenger Van	\$28,000.00	\$6,700.00	\$3,350.00	\$3,350.00
<b>Total</b>	<b>\$83,000.00</b>	<b>\$18,800.00</b>	<b>\$9,400.00</b>	<b>\$9,400.00</b>

\*\* Local Share (approx \$1,100) includes:

(Signage, Mounts, Radio, Antenne, Mirror, Running Boards and Installation)

### Current Vehicles in Lexington Fleet

Year	Make	Model	Mileage as of 3/31/2016
2001	Chevy	Cutaway	149396
2004	Ford	Cutaway	114318
2009	Chevy	Cutaway	85058
2013	Ford	Cutaway	50181
2009	Chevy	Cutaway	122773
2000	Ford	Econoline	93974

These two vehicles were transferred from another fleet

**STARTRANS**

A SUPREME CORPORATION COMPANY

**SENATOR SERIES  
FORD**





# SENATOR SERIES FEATURES

**SUBFLOOR** – 12-gauge steel outriggers, fully welded with floorlevel Z rail, incorporated with chassis rubber ride capabilities.

**FLOORING** – 3/4" FRP, undercoated. Floor covered with 1/8" transit rubber. Aluminum heat shield over chassis catalytic converter and muffler.

**SIDEWALLS** – 3/4" polyurethane foam insulation (R-6) gelcoated to 1/4" FRP exterior with 1/4" FRP interior. Reinforced with steel perimeter and transverse supports. Completely fiberglassed to adjoining body parts to form a single unitized body.

**ROOF** – One-piece FRP/Nidacore laminate roof with steel cage reinforcement.

**WINDOWS** – 24" x 34" T-slider, 31% tinted. Clamp ring-style radius windows. Egress windows installed to meet FMVSS 217 requirements. Operator's curbside windows AS-2 rated: 442 square inches visibility.

**ENTRY** – Spacious entrance (32" x 83" clear opening) with doors that operate manually or electric. Door panels have full height glass panels for the best possible driver's visibility. White step nosing and lighted stepwell standard. Entrance grab rail (left side).

**LIGHTING** – Each bus comes standard with six passenger courtesy lights.

**ELECTRICAL** – Wiring is color-coded with the number and function designated every 12" on the wire to enable identification and circuit traceability. Only premium components built to meet the Society of Automotive Engineers (S.A.E.) and Underwriter's Laboratories (U.L.) requirements are used. Electronic control console switch panel.

**OPTIONAL A/C & HEAT** – A/C systems ranging in size from 30,000 BTU to 88,000 BTU. Rear heat 20,000 BTU to 65,000 BTU.

**OPTIONAL PARATRANSIT** – Wheelchair accessibility with a wide range of securement systems and seating arrangements.

**OPTIONAL LUGGAGE** – Luggage can be stored in over-seat, floor-to-ceiling, rear compartments or custom-designed areas.

**OPTIONAL SEATING** – Forward-facing, perimeter-style and track seating are all available. Your choice of vinyl and cloth fabric in a wide range of colors.

- Bright white gelcoated body with choice of three standard striping packages.
- Black exterior mirrors – 8" x 15
- Heavy-duty 10-gauge wraparound bumper with anti-ride cover.
- Mud flaps (front and rear).
- 12-month/12,000 mile with five-year/75,000-mile warranty of body structure.

## FORD SPECIFICATIONS

- E350 and E450 cutaway
- Tinted glass
- Automatic transmission
- 4:10 and 4:56 rear axle ratio
- Power steering
- Power brakes (4 wheel disc)
- Dash A/C and heater
- Auxiliary transmission cooler (gas chassis only)
- Super engine cooling
- Tilt steering and cruise control
- 5.4 or 6.8 gas engine and 6.0 diesel
- 37-gallon fuel capacity on E350
- 55-gallon fuel capacity on E450
- Radial tires LT225-16 E
- Chrome front bumper
- Comfort ride suspension – H.D. springs and shocks
- Engine oil cooler (diesel chassis only)
- Engine gauges
- Heavy-duty batteries
- Dual 140 & 120 amp – diesel  
Single 135 amp – gas
- 138", 158" or 176" wheelbase
- GVWR 11,500 to 14,500

## Dimensions

- Exterior width – 96"
- Exterior height – 114"
- First step to ground – 11½" second and third step riser – 9" max.
- Step tread depth – 9" max.
- Entrance clear opening – 32" x 83" min.
- Interior width at seat level – 92½"
- Interior width up 36" from floor – 93¾"
- Center aisle height – 80½"
- Flat floor aisle height – 75"
- Double wheelchair doors – 46" x 70.5"
- Rear luggage compartment – 141 cubic feet (standard)

Due to Supreme Corporation's commitment to product quality, specifications and options are subject to change in the interest of product improvement and market changes.

Floorplans shown are only a few of the designs available.

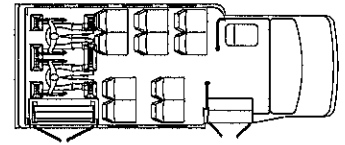

10 Passengers and 2 W/C

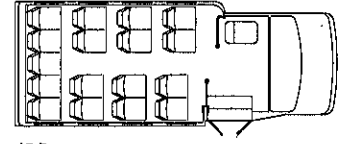

17 Passengers

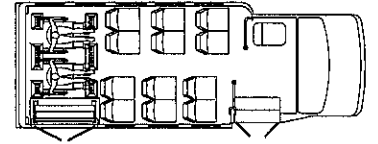

12 Passengers and 2 W/C

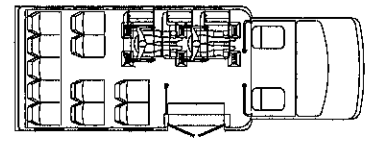

11 Passengers and 2 W/C (UFL)

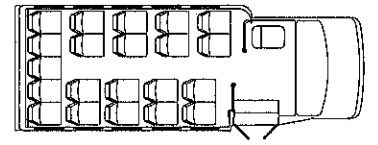

21 Passengers

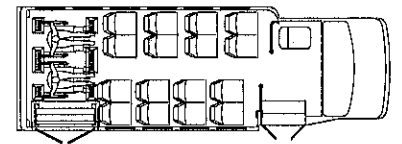

16 Passengers and 2 W/C

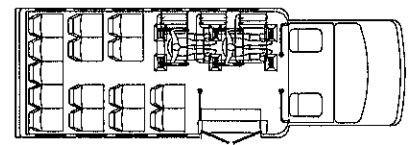

15 Passengers and 2 W/C (UFL)

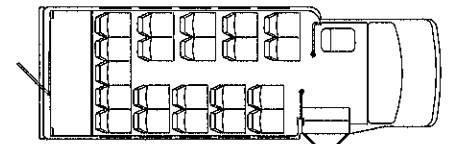

21 Passengers w/luggage

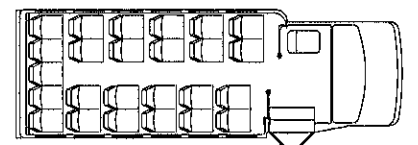

25 Passengers



2592 East Kercher Road • Goshen, IN 46528  
574-642-4730 • 877-258-1391 • FAX 574-642-4108  
www.StarTransBus.com



Please call today for a dealer near you.

**FEATURES:**

- 24"x34" T-SLIDER WINDOWS
- L-TRACK (FLANGED) OTHERS AVAILABLE

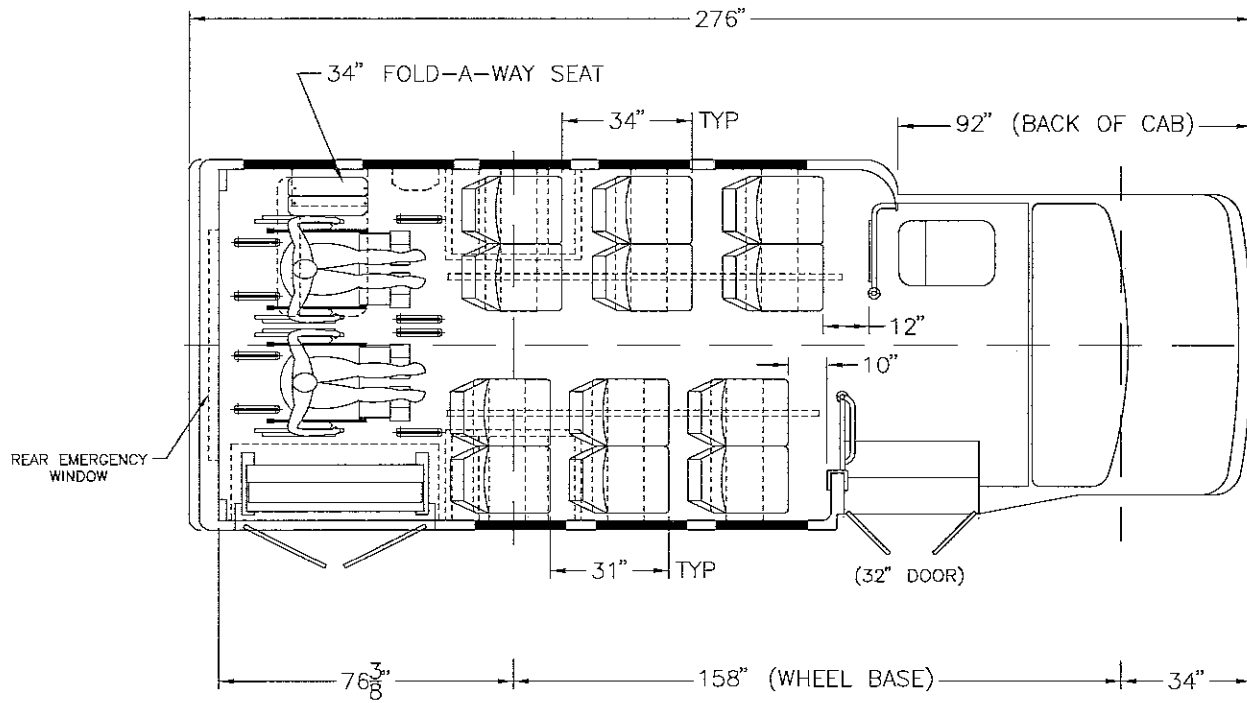
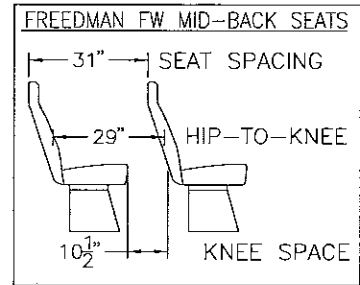

**TOLERANCES**  
 FLOORPLAN DIMS: +/- 1/8"  
 FRACTIONAL DIMS: +/- 1/16"  
 2 PLACE DECIMAL DIMS: +/- .01"  
 3 PLACE DECIMAL DIMS: +/- .005"

AVAILABLE ALSO ON THE E450 6.8G CHASSIS

THE SUPREME CORP. CLAIMS PROPRIETARY RIGHTS IN THE MATERIAL DISCLOSED HEREON. NEITHER THIS DRAWING NOR ANY REPRODUCTION THEREOF MAY BE USED TO MANUFACTURE ANYTHING SHOWN HEREON WITHOUT PERMISSION IN WRITING FROM SUPREME CORP. TO THE USER SPECIFICALLY REFERRING TO THE DRAWING.

WAW=OK (14,500 GVWR)

		DRAWN		 <p>STARTRANS                  TRANSIT BUS DIVISION                  GOSHEN, IN 46526</p>	MODEL: FORD	TITLE (OR COMMENTS):	PART NUMBER:
		BY	Tom Vandenburger		E450 6.0D	12 + 2 PASS & 2 W/C, REAR LIFT	QUOTE
		DATE	4/1/06	DWG SCALE:	SERIES:	FILE LOC & FILE NUMBER:	
LET.	REVISION DESCRIPTION	BY	DATE	PLOT SCALE:	BS22 SENATOR PARATRANSIT	BS22 E450 12P+2S 2WC RL	
				3/8" = 1'			
				1" = 48"			

# EXPRESS PASSENGER VAN DRIVEN WITH CONFIDENCE.



**IT'S A SURE THING.** When you're transporting people for a living, safety is a priority. The Chevy Express Passenger Van offers standard safety features such as head-curtain side-impact air bags,<sup>1</sup> the StabiliTrak Electronic Stability Control System, a Tire Pressure Monitoring System (except spare tire) and antilock brakes. Enhanced Technology Glass

(ETG)<sup>2</sup> prevents glass from shattering in the event of a collision and helps to keep occupants safe inside the vehicle.

**PLENTY OF PASSENGER SEATING.** The choice of 8-, 12- and available 15-passenger seating configurations (depending on model) allows you to easily tailor the Express Van to your exact needs.

**SECURITY ZONE.** A rear vision camera and Rear Park Assist are available and help detect stationary objects behind the vehicle when traveling in reverse at low speeds. With dual-stage frontal air bags,<sup>3</sup> driver and front-seat passenger seat-mounted side-impact air bags, and head-curtain side-impact air bags, you're surrounded by features and

technologies that help keep you and your passengers safe.

**EXPRESS HAS TECHNOLOGY COVERED.**

These vans include a 120-volt outlet to help keep laptops, phones and other mobile devices charged. Express provides the amenities you need to help make your job easier, without sacrificing durability.

CHEVY COMMERCIAL VAN MODEL	TRIM/SERIES	DRIVE	WHEELBASE (WB)	STANDARD ENGINE	STANDARD HP @ RPM/LB.-FT. TORQUE @ RPM	OPTIONAL ENGINES	MAXIMUM PAYLOAD <sup>1</sup>	CARGO SPACE <sup>2</sup> (CU. FT.)	STANDARD SEATING	OPTIONAL SEATING
EXPRESS CARGO VAN	2500 Regular	RWD	135"	Vortec 4.8L V8	285 @ 5400/295 @ 4600	Vortec 6.0L V8, Vortec 6.0L V8 (CNG), Duramax 6.6L Turbo-Diesel V8	3,191 lbs.	239.7	2	1/5
	2500 Extended	RWD	155"	Vortec 4.8L V8	285 @ 5400/295 @ 4600	Vortec 6.0L V8, Vortec 6.0L V8 (CNG), Duramax 6.6L Turbo-Diesel V8	2,978 lbs.	284.4	2	1/5
	3500 Regular	RWD	135"	Vortec 4.8L V8	285 @ 5400/295 @ 4600	Vortec 6.0L V8, Vortec 6.0L V8 (CNG), Duramax 6.6L Turbo-Diesel V8	4,145 lbs.	239.7	2	1/5
	3500 Extended	RWD	155"	Vortec 4.8L V8	285 @ 5400/295 @ 4600	Vortec 6.0L V8, Vortec 6.0L V8 (CNG), Duramax 6.6L Turbo-Diesel V8	3,951 lbs.	284.4	2	1/5
EXPRESS COMMERCIAL CUTAWAY	3500	RWD	139"/159"	Vortec 4.8L V8 <sup>3</sup>	285 @ 5200/295 @ 4600	Vortec 6.0L V8, Duramax 6.6L Turbo-Diesel V8	5,381 lbs./ 5,100 lbs.	—	2	1
	3500	RWD	177"	Vortec 6.0L V8	342 @ 5400/373 @ 4400	Duramax 6.6L Turbo-Diesel V8	7,248 lbs.	—	2	1
	4500	RWD	159"/177"	Vortec 6.0L V8	342 @ 5400/373 @ 4400	Vortec 6.0L V8 (LPG) (159" WB only), Duramax 6.6L Turbo-Diesel V8	9,156 lbs./ 8,868 lbs.	—	2	1
EXPRESS PASSENGER VAN	2500	RWD	135"	Vortec 4.8L V8	285 @ 5200/295 @ 4600	Vortec 6.0L V8	2,705 lbs.	216.2 <sup>4</sup>	12	8
	3500 Regular	RWD	135"	Vortec 4.8L V8	285 @ 5200/295 @ 4600	Vortec 6.0L V8, Duramax 6.6L Turbo-Diesel V8	3,491 lbs.	216.2 <sup>4</sup>	12	8
	3500 Extended	RWD	155"	Vortec 4.8L V8	285 @ 5200/295 @ 4600	Vortec 6.0L V8, Duramax 6.6L Turbo-Diesel V8	3,197 lbs.	252.8 <sup>4</sup>	12	15
CITY EXPRESS	—	FWD	115.2"	2.0L I-4	131 @ 5200/139 @ 4900	—	1,500 lbs.	122.7	2	—

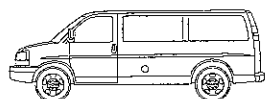

Express Cargo Van

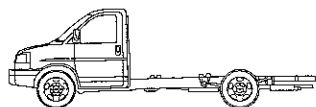

Express Commercial Cutaway

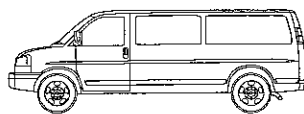

Express Passenger Van



City Express

<sup>1</sup> These maximum payload ratings are intended for comparison purposes only. Before you buy a vehicle or use it to haul people or cargo, carefully review the Vehicle Loading section of the Owner's Manual and check the carrying capacity of your specific vehicle on the label on the inside of the driver door jamb. <sup>2</sup> Cargo and load capacity limited by weight and distribution. <sup>3</sup> On vehicles weighing less than 10,000 lbs. <sup>4</sup> With all rear passenger seats removed.

**EXPRESS PASSENGER VAN SELECT SPECIFICATIONS** ● STANDARD ○ AVAILABLE – NOT AVAILABLE

ENGINE AVAILABILITY	HP @ RPM	LB.-FT. TORQUE @ RPM	2500	3500	3500 EXT
Vortec 4.8L V8	285 @ 5400	295 @ 4600	●	●	●
Vortec 6.0L FlexFuel <sup>1</sup> V8	342 @ 5400	373 @ 4400	○	○	○
Vortec 6.0L V8 (CNG)	282 @ 4700	320 @ 4400	○	○	○
Duramax 6.6L Turbo-Diesel V8	260 @ 3100	525 @ 1600	–	○	○

TRANSMISSION/TRANSFER CASE AVAILABILITY	2500	3500	3500 EXT
Hydra-Matic 6-speed automatic with overdrive, Tap-Up/Tap-Down Driver Shift Control, auto grade braking and Tow/Haul mode	●	●	●

CHASSIS FEATURES	2500	3500	3500 EXT
Alternator: 105-amp	●	●	●
145-amp	○ <sup>2</sup>	○ <sup>2</sup>	○ <sup>2</sup>
160-amp	○ <sup>3</sup>	○ <sup>3</sup>	○ <sup>3</sup>
Battery: 600-cca <sup>4</sup>	●	●	●
Heavy-duty 770-cca <sup>4</sup>	○ <sup>5</sup>	○ <sup>5</sup>	○ <sup>5</sup>
Brakes: Power, hydraulic 4-wheel ventilated disc	●	●	●
4-wheel antilock with Dynamic Rear Proportioning	●	●	●
Front rotor diameter and thickness	12.8" x 1.5"	12.8" x 1.5"	12.8" x 1.5"
Rear rotor diameter and thickness	13.0" x 1.1"	13.0" x 1.1"	13.0" x 1.1"
Steering: Power	●	●	●
Oil-Life Monitor	●	●	●
StabiliTrak Electronic Stability Control System	●	●	●
Differential: Automatic locking rear	○	○	○
Front Gross Axle Weight Rating	4,100 lbs.	4,300 lbs.	4,300 lbs.
Rear Gross Axle Weight Rating	5,360 lbs.	6,084 lbs.	6,084 lbs.

<sup>1</sup> Go to [chevrolet.com/biofuels](http://chevrolet.com/biofuels) to see if there is an E85 fuel station near you. <sup>2</sup> Included with available rear air conditioning. <sup>3</sup> Requires dual 770-cca batteries. <sup>4</sup> Cold-cranking amps. <sup>5</sup> Duramax 6.6L Turbo-Diesel V8 engine comes with standard dual 770-cca batteries. <sup>6</sup> GM is not responsible for the safety or quality of design features, materials or workmanship of any alterations by such a supplier.



**MOBILITY VEHICLES.** We want to make it easy and safe for people with special needs (and those who care for them) to travel. Chevy Express provides abundant interior space and accessibility that wheelchair and scooter users appreciate. Express is a practical choice for mobility

and paratransit conversions. It's designed to allow easy installation of adaptive equipment and mobility accessories like wheelchair lifts, ramps, running boards and driver aids, available from independent aftermarket suppliers<sup>6</sup>